

RDI, IPR and SMEs

Pawan Dutt,
Taltech,
2023

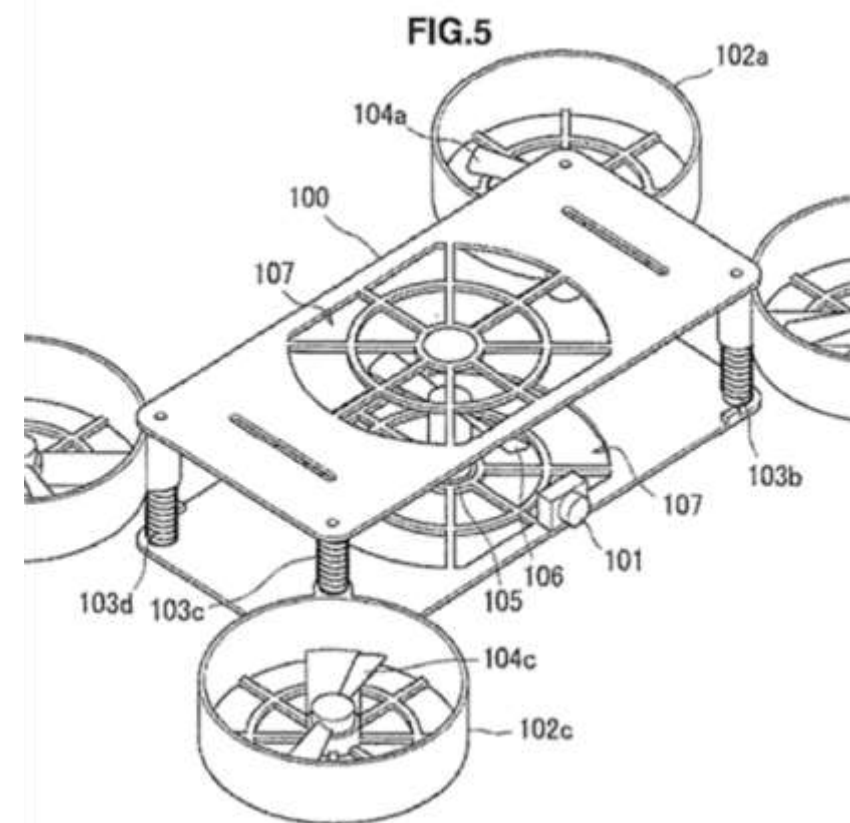

Introduction to IPR

Trade marks, patents, copyrights, designs, geographical indications, trade secrets, etc.

Are IPRs essential? Maybe.

Are they useful? Definitely.

Some IPR Legislation in Europe

- Directive (EU) 2015/2436 relating to trade marks
- European Patent Convention, 1973
- Directive (EU) 2019/790 on copyright and related rights in the Digital Single Market (and many other Copyright related directives)
- Directive 98/71/EC on the legal protection of designs
- Directive (EU) 2016/943 on the protection of trade secrets against their unlawful acquisition, use and disclosure
- Regulation (EU) No 1151/2012 on quality schemes for agricultural products and foodstuffs

2022 INTELLECTUAL PROPERTY SME SCOREBOARD (commissioned by the EUIPO)

Only 10% of SMEs in the EU have at least one IP right registered. Among the reasons for not protecting their IP assets, 1/3 say that they see no extra benefits.



Theoretical aspects of RDI, IPR and SMEs

Entrepreneurship in Networks model

KIRWAN, Paul, VAN DER SIJDE, Peter, GROEN, Aard. Early-Stage Networking: How Entrepreneurs Use Their Social Capital to Establish and Develop High-Technology Start-Ups. In J. Ulijn, D. Drillon, & F. Lasch (Eds.), *Entrepreneurship, Cooperation and the Firm: The Emergence and Survival of High-Technology Ventures in Europe*. Edward Elgar Publishing, 2007, pp. 391-414.

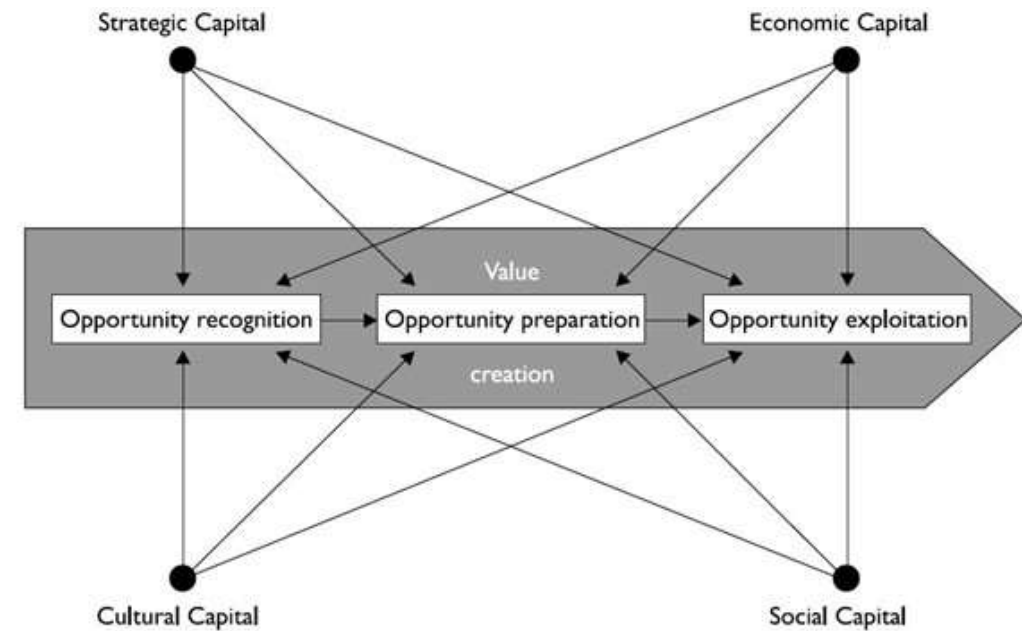

Key attributes related to each of the capitals in the 4 S Model

Dutt, P. K., Nyman-Metcalf, K. and Kerikmäe, T. 2021. A Review of Different Theoretical Approaches towards Sustainable Development Goals in the area of Research, Development and Innovation. *Retfærd*, 4 (167), pp. 89–109.

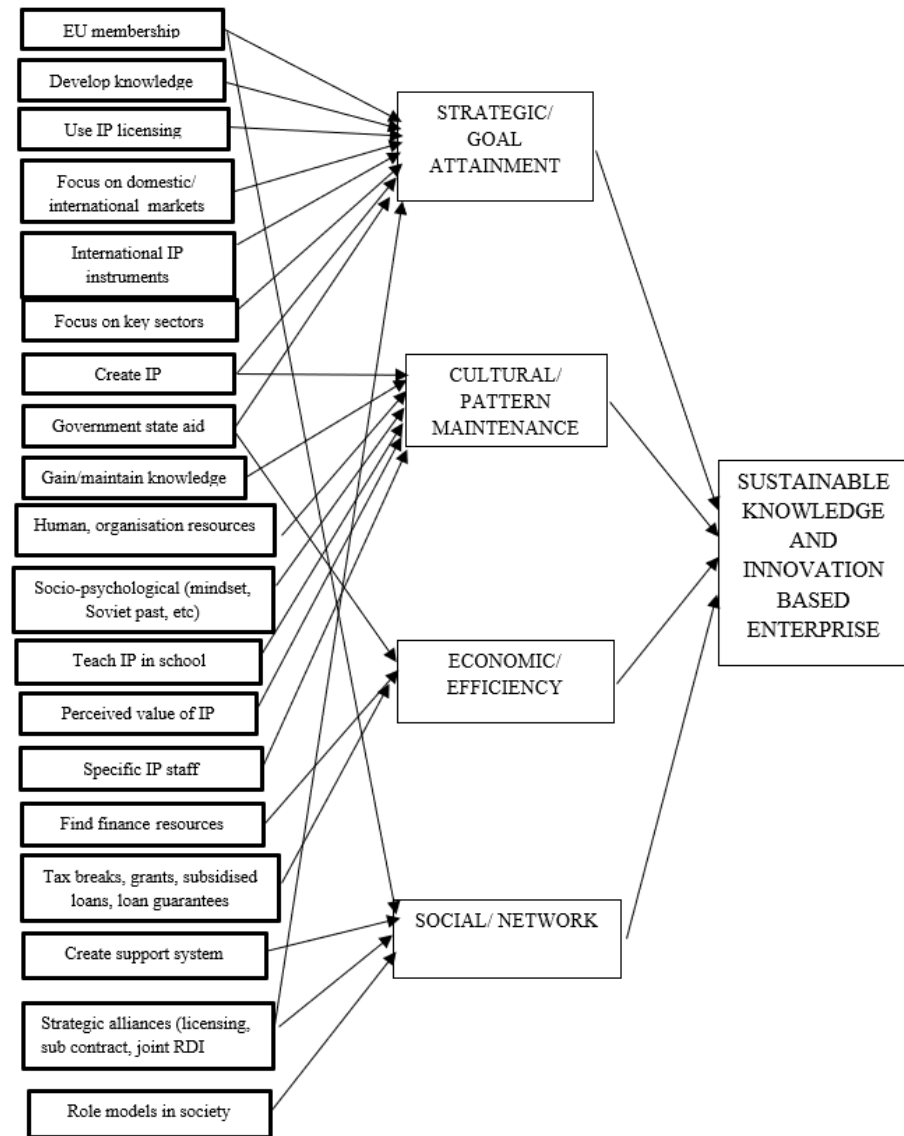

The cumulative effect of social systems and motivation on a knowledge and innovation based enterprise while processing an idea towards value creation through the intermediaries, namely opportunity recognition (OR*), opportunity preparation (OP*) and opportunity exploitation (OE*)

Dutt, P. K. and Nyman-Metcalf, K. 2021. Legal Implications of Public Support Policies targeting Research, Development and Innovation in the European Union, *TalTech Journal of European Studies* Vol. 11, No. 2(34), pp. 102-129

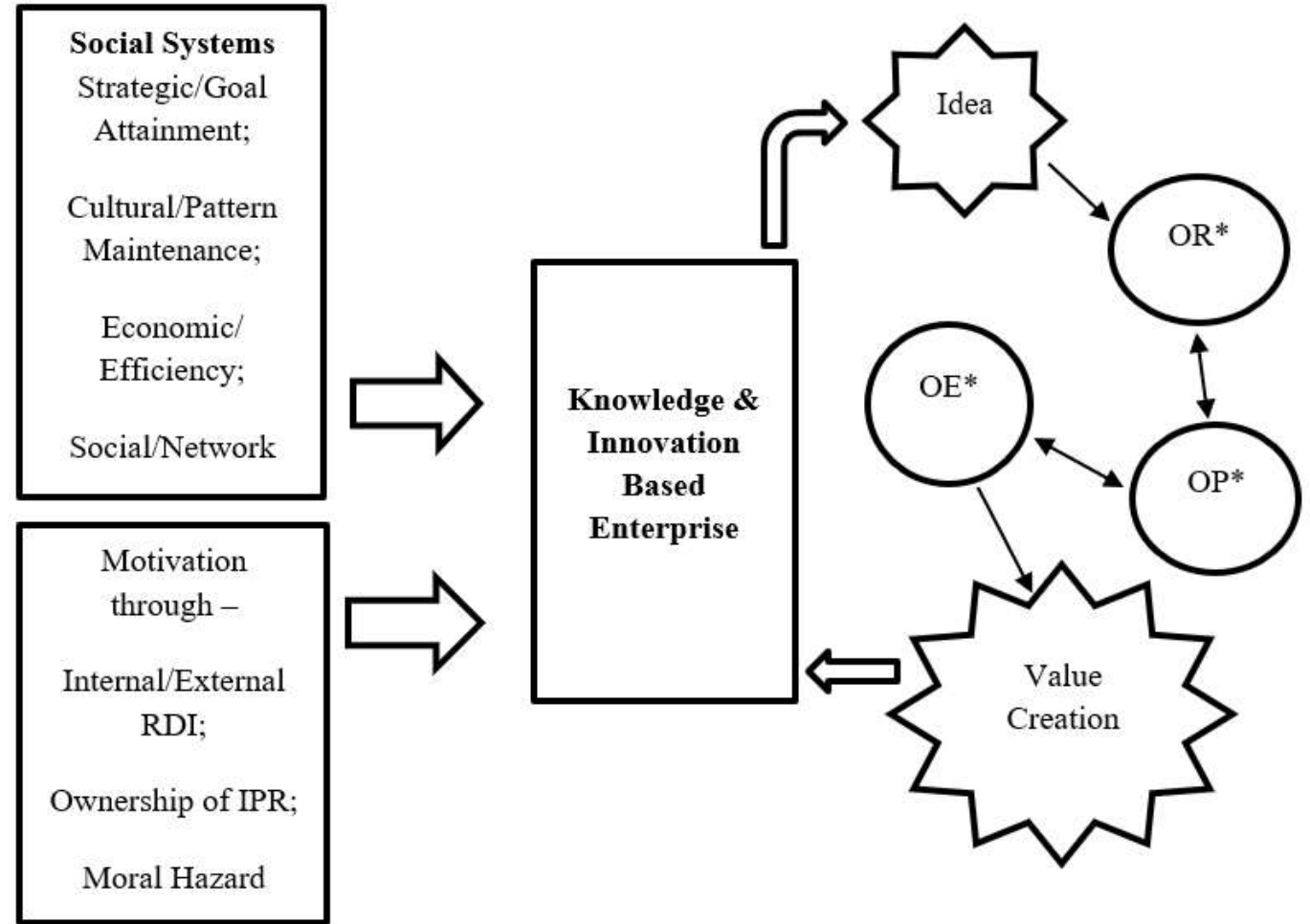

Estonian RDIE Strategy



Estonian Research and
Development, Innovation
and Entrepreneurship

Strategy
2021—2035

The triple axes

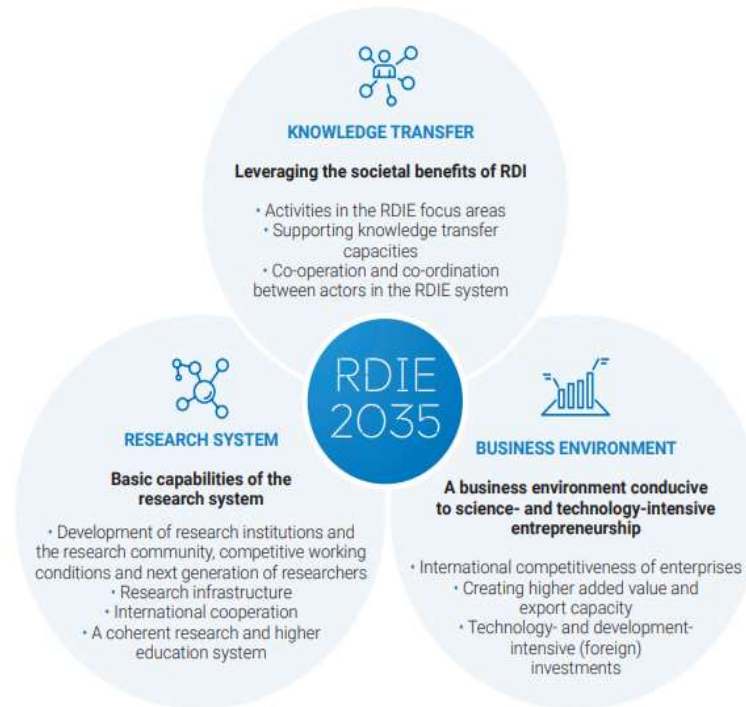

Some modern IP opportunities for SMEs in EU: Unitary Patent and Unitary Patent Court (reduced costs, greater territorial coverage, legal certainty)

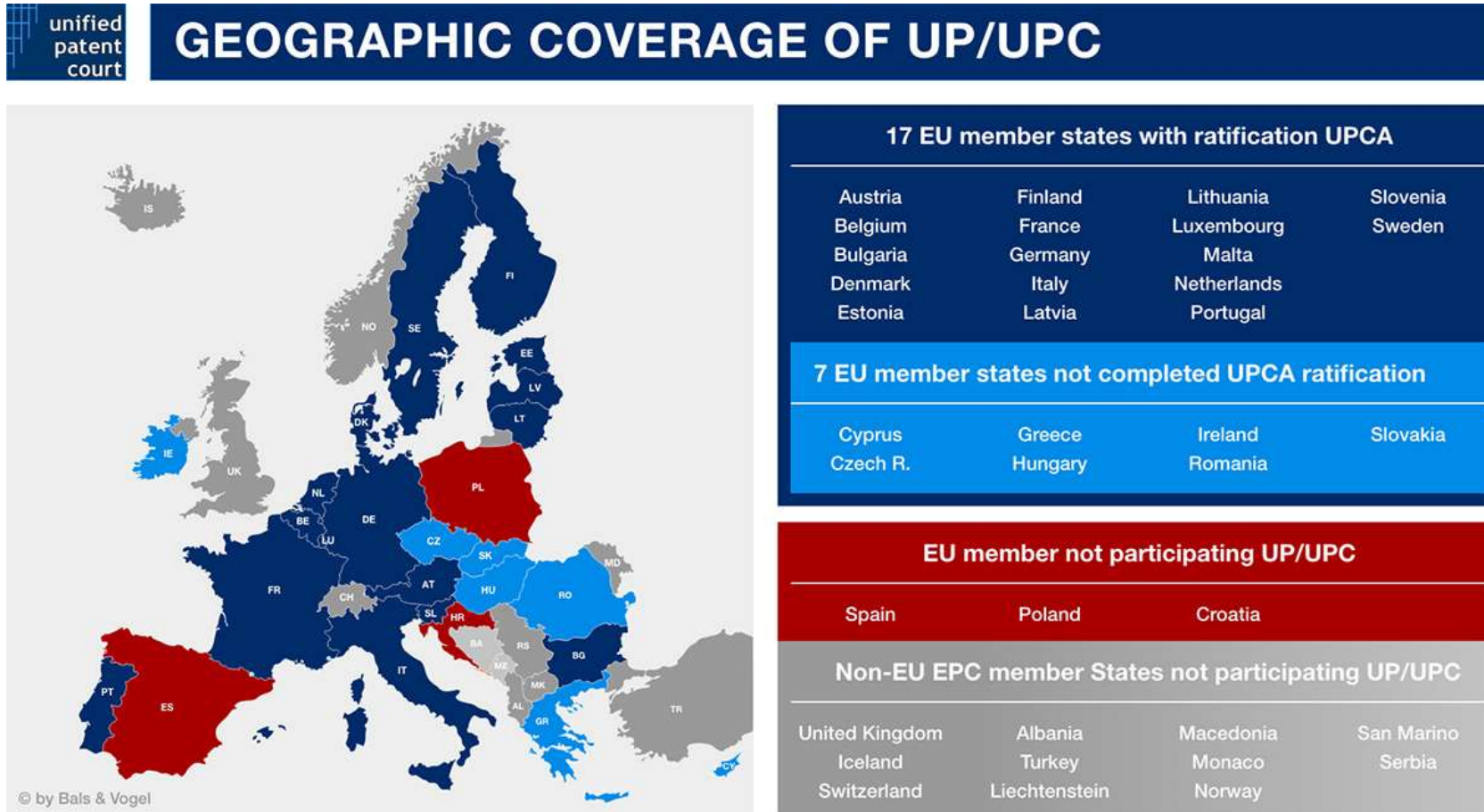

Modern IP challenges for SMEs in EU

Cost escalations, high entry costs, greater legal compliance, etc

- Digital IP
- Digital Services Act
- Digital Markets Act

➔ Defining “Internet intermediaries”

- Platforms and conduits for expression, A2K, association, and commerce

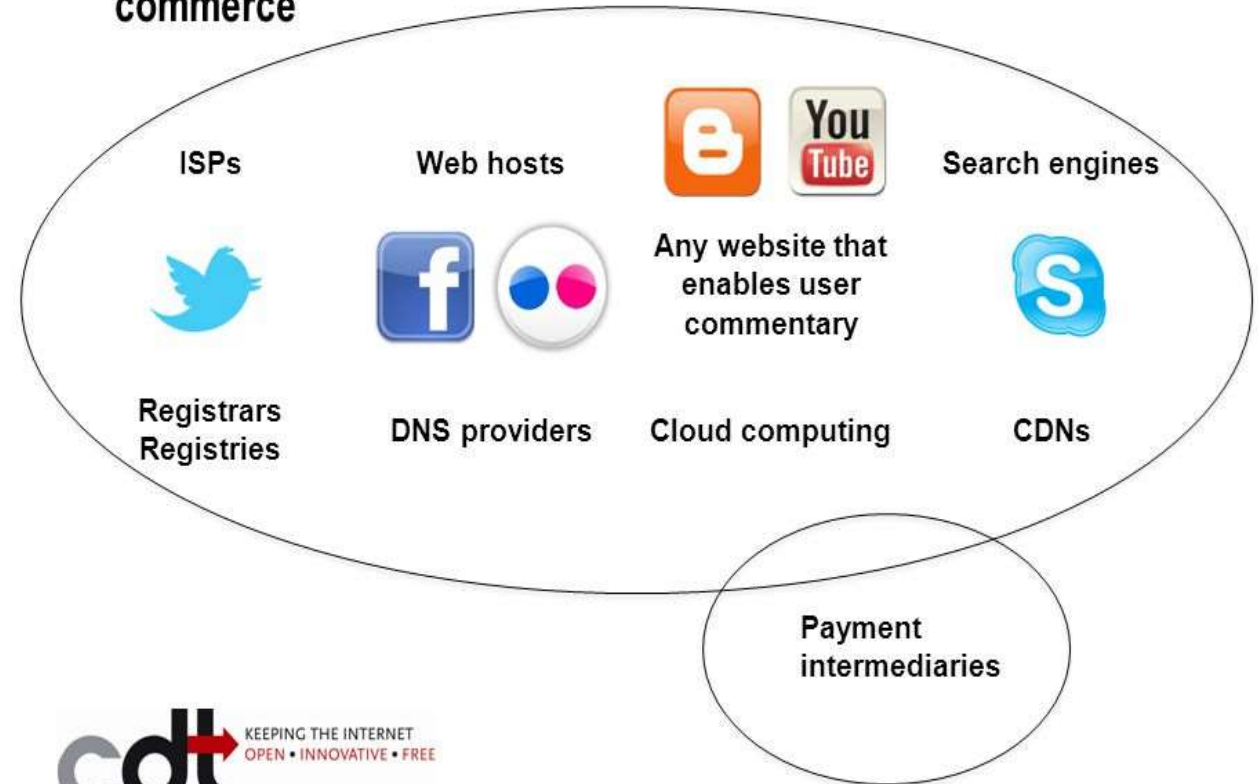

EPO SME case studies

<https://www.epo.org/learning/materials/sme/innovation-case-studies/sme-case-studies.html>

The EPO SME case studies

- **Demonstrate that European SMEs**
 - can create strategic value from patents
 - need to know when and how to use patents to support their business
 - will benefit from the Unitary Patent and Unified Patent Court
- **Facilitate the transfer of know-how about IP strategy and IP management by**
 - showing concrete business examples
 - creating a pool of IP experts and SMEs for dissemination activities

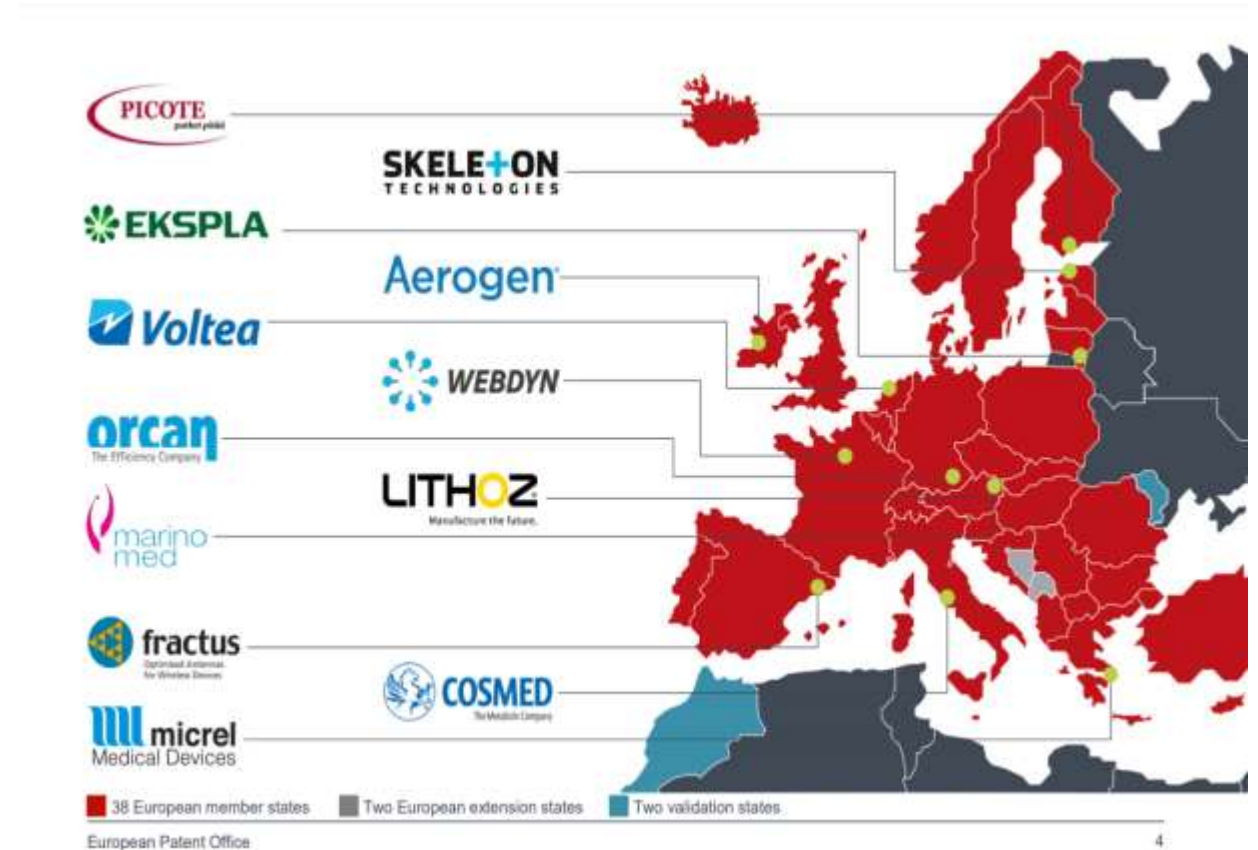

Outside EU: VR Films and Studios Ltd

Motion picture and video distribution company in South Asia
Proprietorship firm – private company – IPO for SME Board –
migration to BSE – future?

Market Summary > VR Films & Studios Ltd

49.96 INR

+42.46 (566.13%) ↑ past 5 years

Aug 21, 14:03 GMT+5:30 • Disclaimer

1D 5D 1M 6M YTD 1Y **5Y** Max

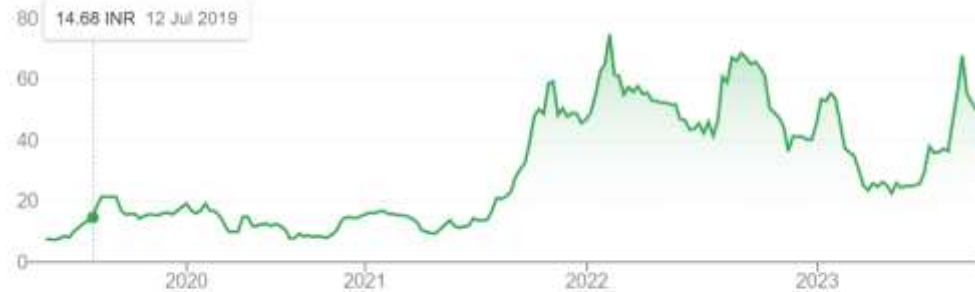

Open	-	Mkt cap	548.36M	52-wk high	75.00
High	-	P/E ratio	533.82	52-wk low	20.42
Low	-	Div yield	0.50%		

SILENT STORM

Heart Beat

FOR THE LOVE OF JUSTICE

VR OTT

Watch on VROTT Superhit Turkish Series
In Hindi, Tamil, Telugu

CITY OF SECRETS

Thank you!